

Connect

AUTOMATION

STAINLESS STEEL MODULAR BELT CONVEYOR

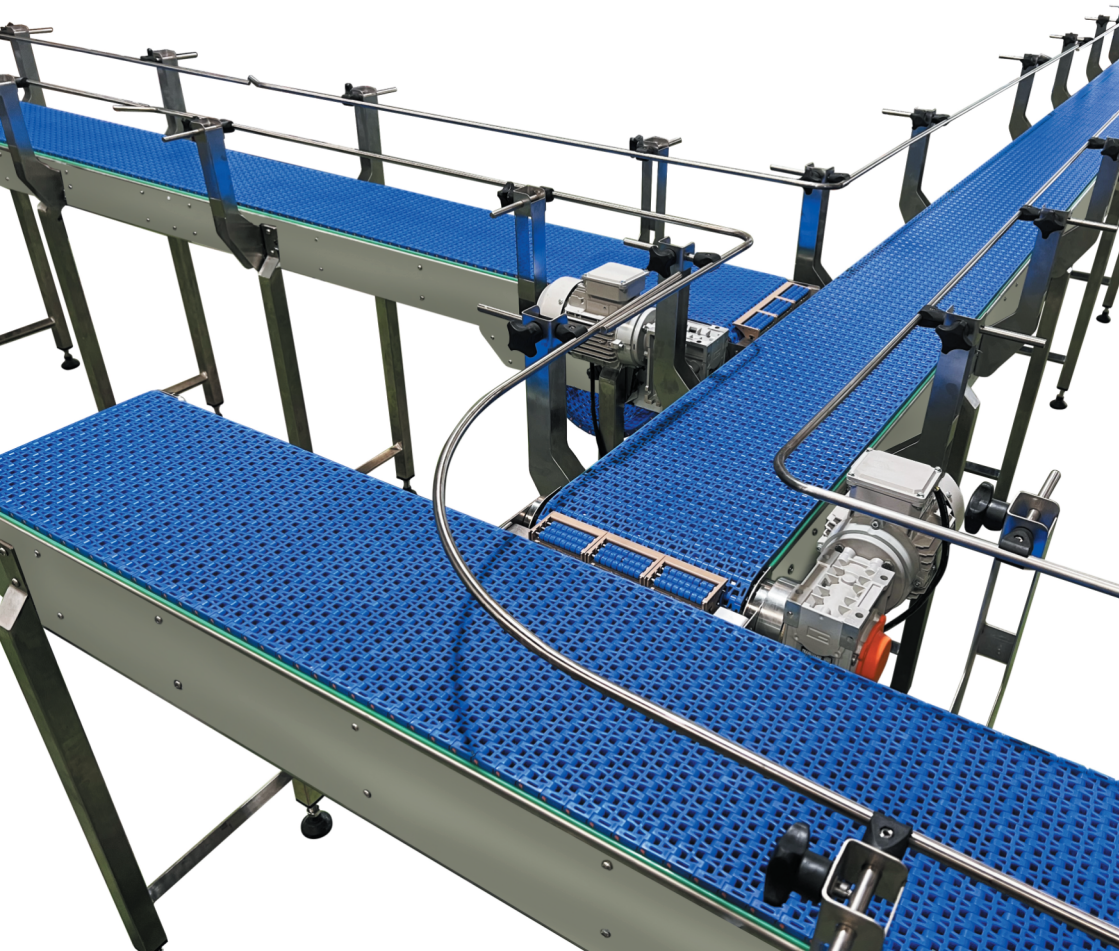



ISO 9001:2015

Certificate Number : QCSMPL/INT/Q/A/0241

Company Policies :



**INTEGRITY
POLICY**



**QUALITY
POLICY**



**HEALTH, SAFETY
AND ENVIRONMENT
POLICY**



**SUSTAINABILITY
POLICY**

Connect Automation
Stainless Steel Modular Plastic Belt Conveyor
Ver 2.2 INA

Semua teks, representasi, ilustrasi dan gambar termasuk sistem panduan adalah kekayaan intelektual dari Connect Automation, PT. Envirooneer.

Dilarang memproduksi ulang bagian brosur atau dikirim dalam bentuk apa pun secara elektronik, mekanik, fotokopi atau sebaliknya, tanpa izin tertulis sebelumnya dari pihak PT. Envirooneer.

Semua data teknis dapat berubah sewaktu-waktu menurut pembaruan teknis terbaru.

**Scan untuk
Mengunjungi
Website Kami :**



DAFTAR ISI

Tentang Stainless Steel Modular Belt Conveyor	1
Aturan Sistem Pengangkutan	2
Portofolio Stainless Steel Modular Belt Conveyor	3
Spesifikasi Teknik	4
Pilihan Macam Aksesoris	6

TENTANG MODULAR BELT CONVEYOR

PENGERTIAN MODULAR PLASTIC BELT CONVEYOR

Modular conveyor adalah conveyor yang belt-nya terdiri dari susunan modul-modul plastik yang dirakit menjadi satu menggunakan tangkai penyambung.

MENGAPA HARUS MENGGUNAKAN CONVEYOR MODULAR?

- Belt pada modular conveyor terdiri dari modul-modul plastik yang disusun menjadi satu belt, sehingga mudah dan cepat untuk dipasang. Selain itu modular conveyor juga memiliki kapasitas beban yang lebih tinggi dibandingkan belt conveyor biasa.
- Jika terdapat kerusakan pada bagian belt, perbaikan atau penggantian hanya dilakukan pada modul-modul yang terkena kerusakan saja sehingga sangat menghemat biaya dan meminimalisir waktu *down-time* atau waktu yang diperlukan untuk perbaikan.
- Modul-modul plastik yang digunakan pada modular conveyor sangat mudah dibersihkan dan tidak menyerap cairan maupun zat lain yang dapat mengandung bakteri, sehingga sangat cocok digunakan untuk industri yang mengharuskan kebersihan pada mesin dan alat-alatnya seperti industri makanan minuman, kosmetik dan farmasi.

CONTOH INDUSTRI YANG IDEAL



F&B



Farmasi



Kosmetik
Body Care



Frozen Food



Pengolahan
Daging

ATURAN SISTEM PENGANGKUTAN



STRAIGHT

- Lebar minimal 300mm, di bawah 300mm dapat menggunakan Table Top Chain
- Panjang minimal 1000mm
- Panjang maksimal 18000mm dengan 1 drive

CURVE & U-TURN

- Lebar minimal 150mm
- Panjang minimal setelah dan sebelum belokan minimal 700mm
- Lebar radius $1\frac{1}{2}$ atau 2 kali lebar belt
- Panjang conveyor dari sebelum dan sesudah sudut belok / U-Turn minimal 700mm

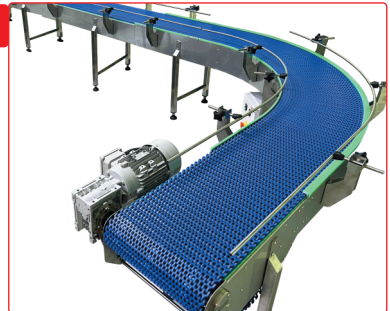

INCLINE & DECLINE

- Untuk incline posisi motor berada di atas
- Untuk decline posisi motor berada di bawah
- Sudut kemiringan normalnya 5°
- Jika menggunakan **rubber top**, sudut kemiringan bisa mencapai 15° (d disesuaikan dengan ketinggian dan jenis barang yang ditransfer)

**PORTOFOLIO STAINLESS STEEL
MODULAR BELT CONVEYOR**

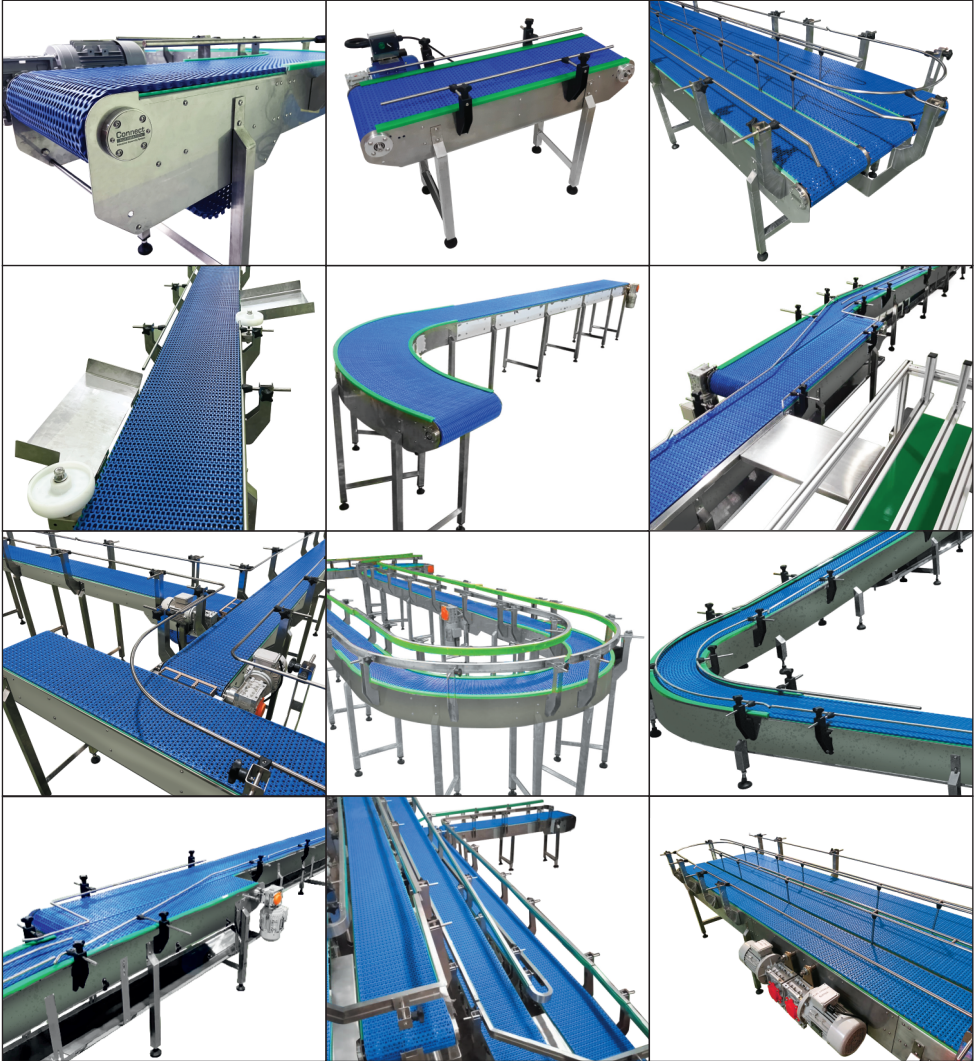

SPESIFIKASI TEKNIK

BODY AND BELT

- Dalam satu unit body conveyor modular terdiri dari **drive** dan **idler**
- **Drive** adalah bagian modular yang terdapat motor penggerak, dengan panjang minimal 600mm
- **Idler** adalah bagian ujung atau ekor modular dengan panjang minimal 400mm
- Letak motor berada di ujung dengan cara menarik belt bukan dengan mendorong (Lihat gambar arah transfer di bawah ini)
- Panjang minimal body conveyor 1000mm, sedangkan panjang maksimal ideal total body conveyor adalah 18000mm
- Body conveyor tersegmentasi menjadi 1200mm atau 2400mm, untuk mengoptimalkan material sheet
- Belt plastic food grade, dengan pilihan warna biru atau putih

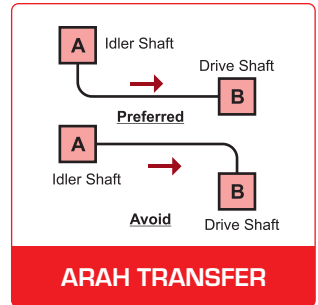
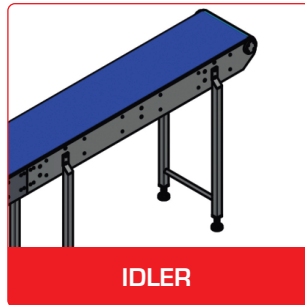
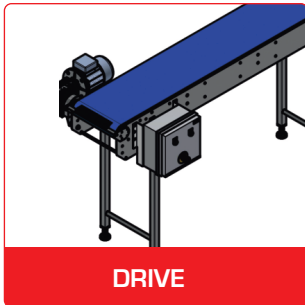

LEGS

Opsi kaki yang dapat dipilih adalah sebagai berikut :

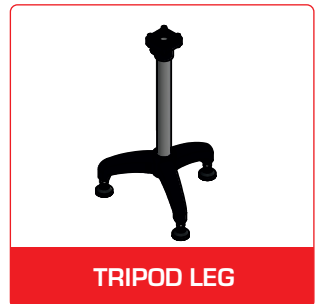
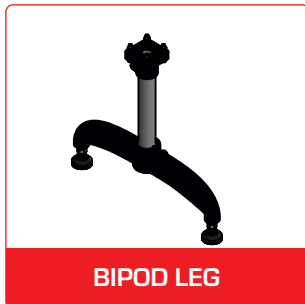
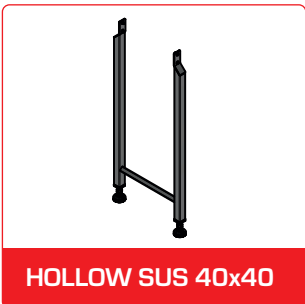

SPEKIFIKASI TEKNIK

TRANSISI

Agar perpindahan barang antar conveyor modular dapat berjalan lancar, sistem transisinya menggunakan bantuan :

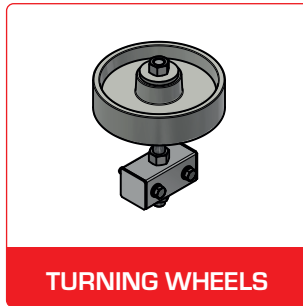
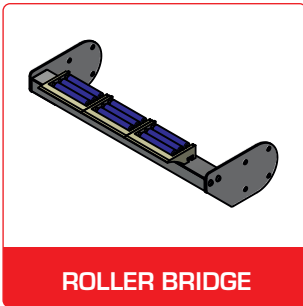

SISTEM TRANSFER

Tipe perpindahan conveyor dibagi menjadi 3 macam, yaitu side transfer, dynamic transfer dan inline transfer.

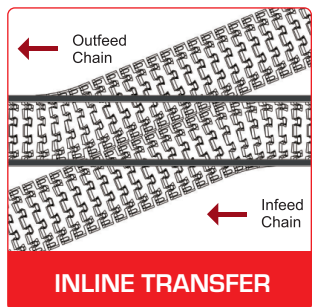
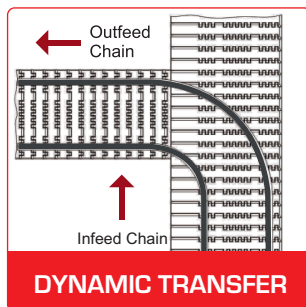
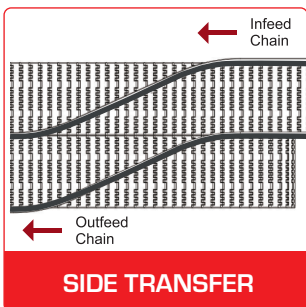

SPESIFIKASI TEKNIK

MOTOR & ELECTRICAL

- Motor 3 phase + Inverter
- Scan QR Code di bawah ini untuk mengetahui tabel kecepatan dan untuk menentukan ratio gearbox yang dibutuhkan

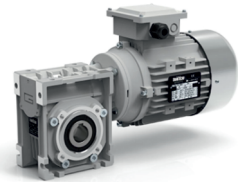

MOTOR 3 PHASE



INVERTER

SCAN ME FOR DETAILS:



TABLE SPEED

PILIHAN MACAM AKSESORIS

SIDE GUIDE

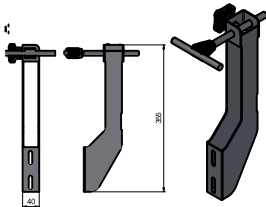

STAINLESS STEEL HOLDER
+ SINGLE ROUND BAR

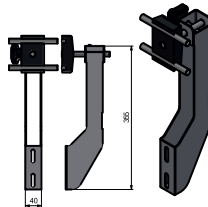

STAINLESS STEEL HOLDER
+ DOUBLE ROUND BAR

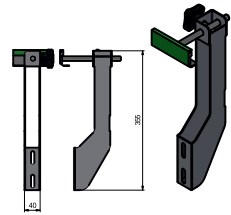

STAINLESS STEEL HOLDER
+ PLATE & WEAR STRIPE

PILIHAN MACAM AKSESORIS

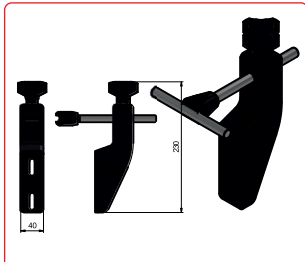

PLASTIC HOLDER
+ SINGLE ROUND BAR

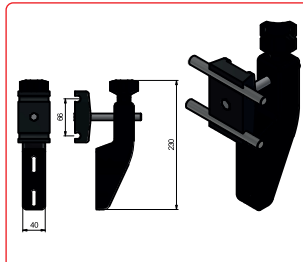

PLASTIC HOLDER
+ DOUBLE ROUND BAR

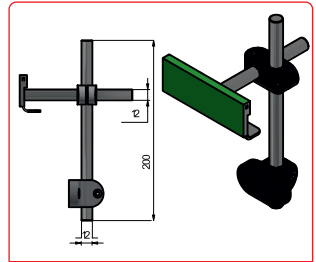

PLASTIC HOLDER CLAMP
+ PLATE & WEAR STRIPE

SENSOR

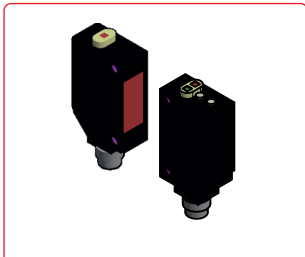

START-STOP /
COUNTER SENSOR

OTHER ACCESSORIES

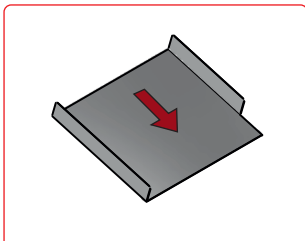

CHUTE

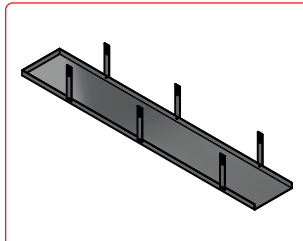

DRIP TRAY

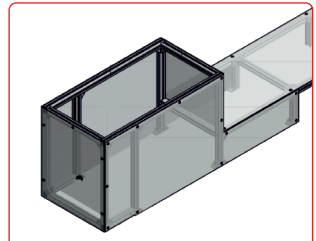

COVER CONVEYOR

KLIEN KAMI



SURABAYA

Jl. Rungkut Industri III/37
Surabaya 60293
Indonesia
T : 031 99858624

JABODETABEK

Kawasan Industri Jababeka Tahap 1
Jl. Jababeka II D Blok C 14 L
Pasir Gombong, Cikarang Utara
Bekasi 17530
T : 021 893 5060

SEMARANG

Ruko Emerald Green Blok A 16
BSB City
Jl. RM Hadi Soebeno
Sosrowardoyo
Semarang 50219
T : 024 76191933

Follow Us

 @connectautomationindonesia

 @ptenvireer